

21 Cylinder head

Professional \ High pressure cleaner cold water \ Electric motor \ HD 6/15 C *EU \ Spare parts list high-pressure 6/15 C *E \ Pump set \ Cylinder head

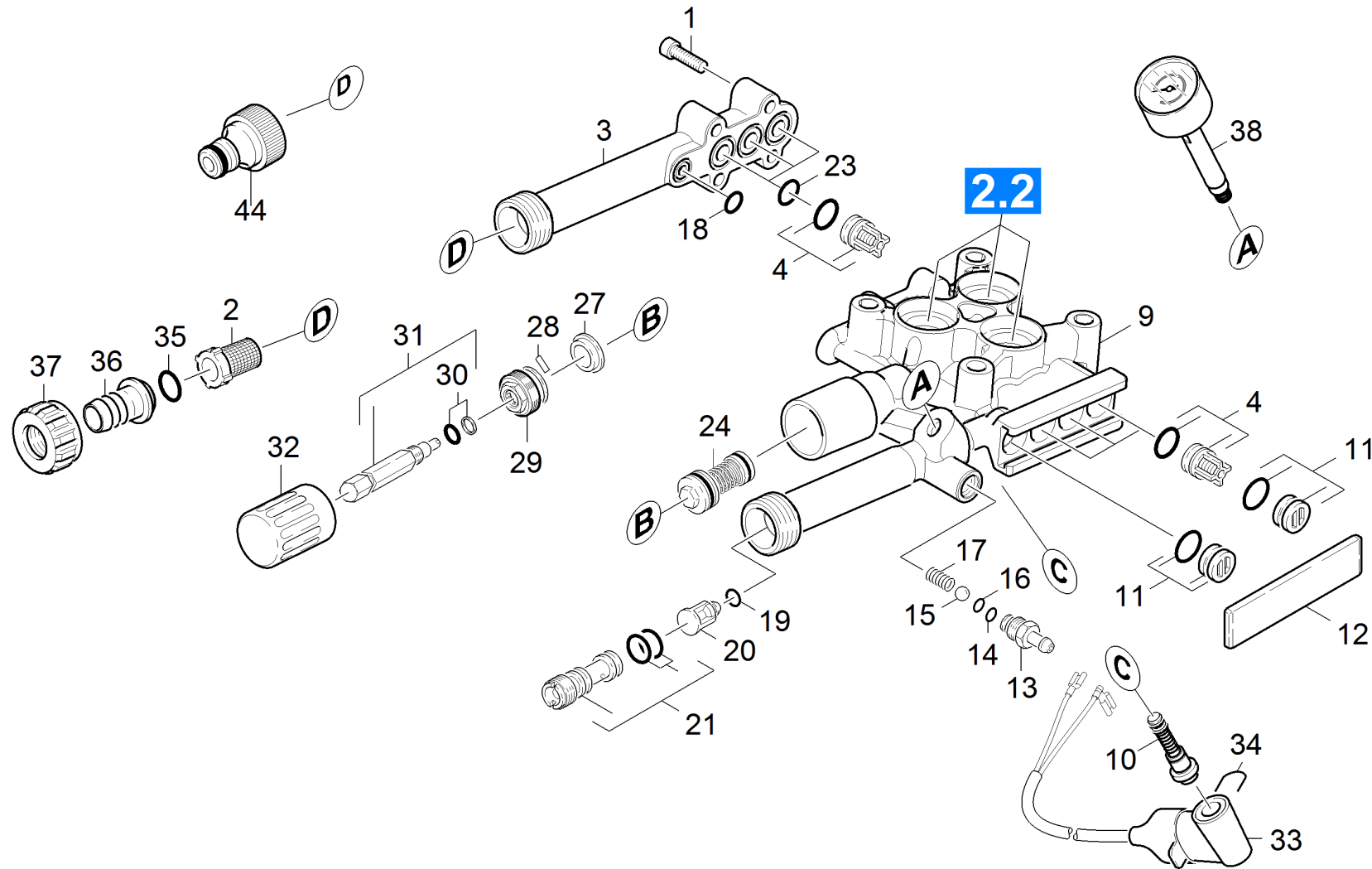

21 Cylinder head

Professional \ High pressure cleaner cold water \ Electric motor \ HD 6/15 C *EU \ Spare parts list high-pressure 6/15 C *E \ Pump set \ Cylinder head

KÄRCHER

POS	Article no.	Description	Quantity	Unit
1	7.306-105.0	Screw M6x30 -8.8-R3R (In6Rd)	4	PC
2	6.414-252.0	Strainer	1	PC
3	5.064-150.3	Inlett fitting for replacement	1	PC
4	2.884-916.0	Valve (3 Stück)	2	PC
9	5.550-025.3	Cylinder head HD 6/15 TR	1	PC
10	2.884-501.0	Spare part set control piston	1	PC
10	2.884-501.3	Spare part set control piston for replacement	1	PC
11	4.132-007.0	Drain plug only for replacement	4	PC
12	5.003-062.0	Plate	1	PC
13	5.443-624.0	Nipple	1	PC
14	6.362-113.0	O-Ring seal 6,0 x 2,0 NBR 70	1	PC
15	7.401-908.0	Sphere 7 G300 -1.4301 DIN 5401	1	PC
16	6.363-597.0	O-Ring seal 5,28 x 1,78	1	PC
17	5.332-258.0	Helical spring	1	PC
18	6.362-384.0	O-Ring seal 9x1,5 - NBR 70	1	PC
19	6.363-613.0	O-Ring seal 4 x 2 -NBR90	1	PC
20	4.584-022.0	Valve pin complete	1	PC
21	4.769-034.0	Nozzle insert only for replacement	1	PC
23	6.362-533.0	O-Ring seal 14,0 X 1,5-NBR 70	3	PC
24	4.591-038.3	Overflow valve for replacement	1	PC
27	5.110-630.0	Sleeve	1	PC
28	7.314-629.0	Grooved pin 2x10 -A1 ISO 8742	1	PC
29	5.583-147.0	Valve screw	1	PC
30	6.362-468.0	O-Ring seal complete 1ST.-R.	1	PC
31	4.291-014.0	Spindle complete	1	PC
32	5.322-095.0	Handhold yellow RAL 1018	1	PC
33	4.744-168.0	Switch complete	1	PC
34	5.034-494.0	Retaining bracket	1	PC
35	6.362-078.0	O-Ring seal 13,3x2,4	1	PC
36	5.443-229.0	Hose stem	1	PC
37	5.310-065.0	Nut	1	PC
38	6.421-349.3	Pressure gauge 0-30 MPa	1	PC
44	6.465-031.0	Connection cpl. 3/4	1	PC

21 Cylinder head

Professional \ High pressure cleaner cold water \ Electric motor \ HD 6/15 C *EU \ Spare parts list high-pressure 6/15 C *E \ Pump set \ Cylinder head

KÄRCHER

POS	Article no.	Description	Quantity	Unit
100	2.885-242.0	Pump set HD 6/15 C	1	PC